

# ACCESSORIES

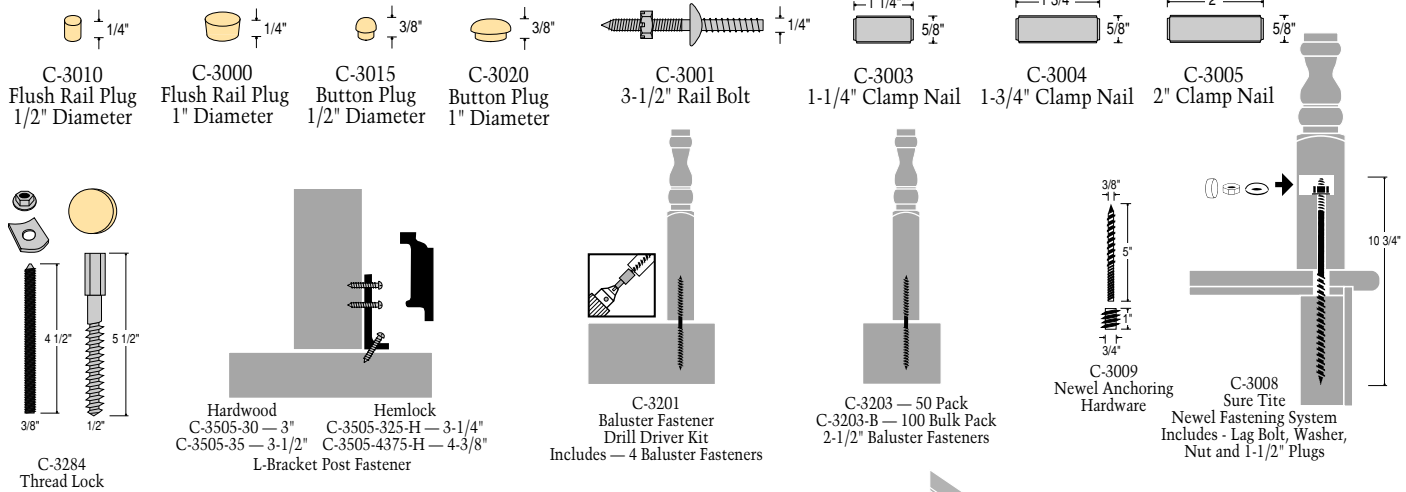

C-3101 Zipbolt UT Rail Bolt

C-3102 Zipbolt Angled Rail Bolt

Ratchet Driver shown with Hex Driver installed (not included).

C-3103 Ratchet Driver

C-3104 Hex Driver - 5mm (3/pack)

C-3105 Allen Wrench-5mm (3/pack)

- Faster, Easier, Gear Driven Rail Bolt Means No Nut To Start
- Tighten Joints Securely With A Driver Or Allen Wrench
- Options Include Angled Rail Bolt For Post-To-Post Rail Connections

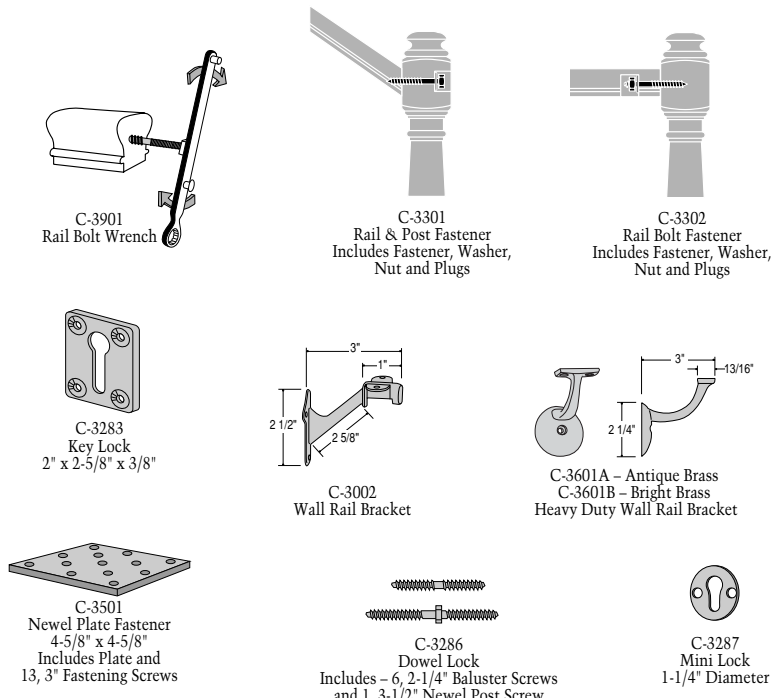

C-3099 Miter Jig

The fastest, easiest and most accurate way to mark and cut fittings.

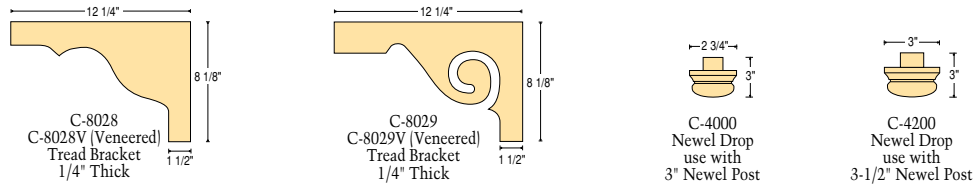

## HARDWOOD

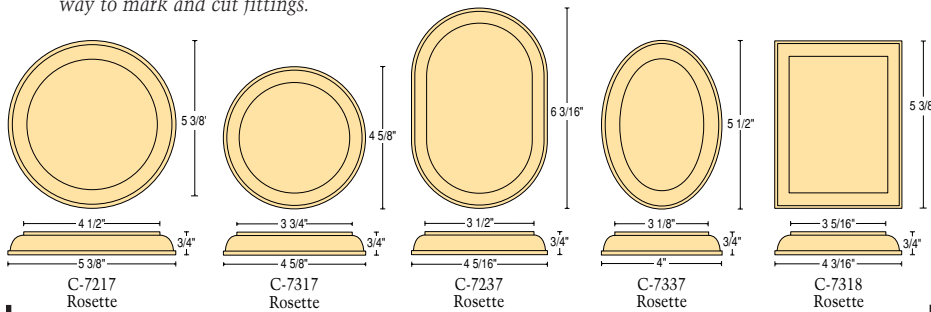

## HARDWOOD

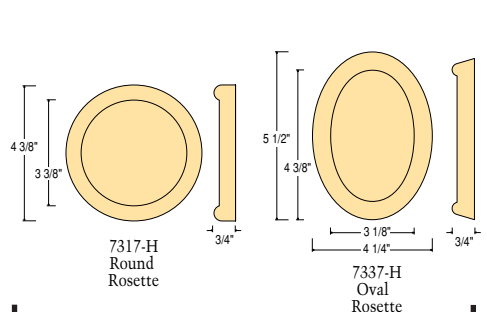

## SOFTWOOD